

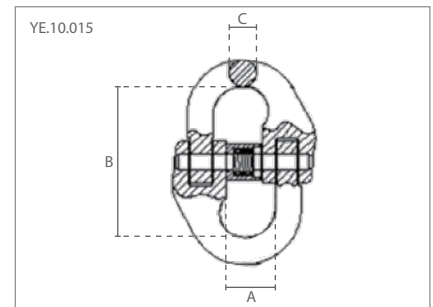

Grade 100 Toebehoren / Grade 100 Accessories

1. Topschalmen / Master links
2. Topschalmen met verloopringen / Master link assemblies
3. Verbindingschalmen / Connecting links

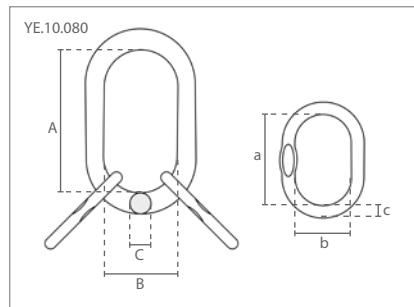
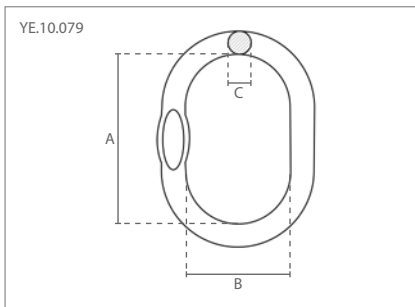

1 Specificaties / Specifications				Afmetingen / Dimensions (mm)		
Artikelnummer	Capaciteit / Capacity	Gewicht / Weight	Markering	A	B	C
Article code	ton	kg	Marking			
YE.10.079.08.06	2.50	0.4	G10 079-08	120	70	14
YE.10.079.10.08	4.00	0.8	G10 079-10	140	80	17
YE.10.079.13.10	7.50	1.5	G10 079-13	160	95	22
YE.10.079.16.13	10.00	2.5	G10 079-16	190	110	28
YE.10.079.20.16	17.00	5.2	G10 079-20	240	140	34
YE.10.079.22.20	25.00	7.7	G10 079-22	250	150	42
YE.10.079.26.22	30.80	12.9	G10 079-26	340	180	45
YE.10.079.32.26	40.00	16.3	G10 079-32	350	190	50
YE.10.079.36	60.00	27.0	G10 079-36	400	200	60

2 Specificaties / Specifications				Afmetingen / Dimensions (mm)					
Artikelnummer	Capaciteit / Capacity	Gewicht / Weight	Markering	A	B	C	a	b	c
Article code	ton	kg	Marking						
YE.10.080.06	3.00	1.3	G10 080-06	135	75	19	84	25	13
YE.10.080.08	5.30	2.4	G10 080-08	160	90	23	70	35	17
YE.10.080.10	8.00	3.7	G10 080-10	180	100	27	85	40	19
YE.10.080.13	14.00	6.5	G10 080-13	200	110	33	115	50	23
YE.10.080.16	21.20	10.1	G10 080-16	260	140	36	140	65	27
YE.10.080.20	33.60	22.8	G10 080-20	350	190	50	150	70	33
YE.10.080.22	39.90	26.0	G10 080-22	350	190	50	180	100	36

3 Specificaties / Specifications			Afmetingen / Dimensions (mm)		
Artikelnummer	Capaciteit / Capacity	Gewicht / Weight	A	B	C
Article code	ton	kg			
YE.10.015.06	1.40	0.1	14	45	8
YE.10.015.08	2.50	0.2	19	62	10
YE.10.015.10	4.00	0.4	23	72	13
YE.10.015.13	6.70	0.7	28	89	17
YE.10.015.16	10.00	1.2	34	103	21
YE.10.015.20	16.00	2.2	42	116	25
YE.10.015.22	19.00	3.0	48	135	27
YE.10.015.26	26.50	5.2	61	164	32
YE.10.015.32	39.30	9.5	80	194	40