



Electrische Kettingtakel US / Electric Chain Hoist US



plug & play afstandsbediening /
plug & play remote control



Eigenschappen

- » Geschikt voor een breed scala aan industriële toepassingen.
- » Mag in geen service-auto ontbreken; maakt uw monteur ARBO-proof.
- » Eenvoudig te bedienen en te transporteren door zijn lage gewicht.
- » Wartel lasthaak met veiligheidsklep.
- » Geleverd klaar voor gebruik met bedieningsschakelaar, voedingskabel en kettingbak.
- » Voldoet aan de Machinerichtlijn 2006/42/EG. Geleverd met testcertificaat, CE-conformiteitsverklaring en gebruiksaanwijzing.

Features

- » Suitable for a wide range of industrial applications.
- » Should not be missing in any service van; makes your service engineer "Health & Safety" proof.
- » Easy handling and high transportability due to low weight.
- » Swivel load hook with safety latch.
- » Supplied ready to use with control switch, power cable and chain container.
- » Complies with the Machinery Directive 2006/42/EC. Supplied with test certificate, CE declaration of conformity and operating instructions.

KARWEITAKEL®
JOBBING HOIST®

CZ.0.US

Specificaties / Specifications							
Artikel nummer	Capaciteit	Hijssnelheid	Hijsketting	Parten	Energie verbruik	Netto gewicht	Extra gewicht
Article code	Capacity	Lifting speed	Load chain	Chains falls	Power output	Net weight	Extra weight
	ton	m/min	Øxmm		kW	kg	kg/m
CZ.0.US.901	0.5	5	6.3 x 19	1	1.3	16	0.9
CZ.0.US.902	1	2.5	6.3 x 19	2	1.3	17	1.8
CZ.0.US.903	1	4	7.1 x 20.2	1	2	26	1.1
CZ.0.US.904	2	2	7.1 x 20.2	2	2	31	2.2

Specificaties / Specifications	
Voltage / Operating voltage	230V / 50-60Hz / 1Ph (110V op aanvraag/on request)
Hijssnelheid / Lifting speed	Enkele snelheid / Single speed
Hijsketting / Load chain	Lastketting volgens EN 818-7-DAT/DT / Load chain according to EN 818-7-DAT/DT
Stuurkabel / Control cable	Standaard ≈6 meter / Standard ≈6 meter
Stroomkabel / Power cable	≈5 meter met stekker / ≈5 meter with plug
Behuizing bescherming / Housing protection	IP 54
Besturing bescherming / Control protection	IP 65
Classificatie / Classification	M4/1Am (ISO/FEM)
Inschakelduur / Starts per uur / Duty cycle / Starts per hour	30% / 180
Isolatieklasse / Insulation class	F
Bedrijfstemperatuur / Operating temperature	-10°C - +40°C
Lading type / Load type	Alleen voor goederen, niet geschikt om personen te hijsen / Goods, may not be used to lift people

Beveiliging / Protection	
Schakelaar / Control switch	230V schakelaar met noodstop / 230V pendant control switch with emergency stop button
Overlastbeveiliging / Overload protection	Extern instelbare slipkoppeling / Externally adjustable slip clutch
Rem / Brake	Mechanische rem / Mechanical brake
Eindschakelaar / Limit switch	US.901 + 902: Geen eindschakelaar, beveiligd door slipkoppeling / No limit switch, protected through slip clutch US.903 + 904: Elektromagnetische hoogste eindschakelaar, laagste positie beveiligd door slipkoppeling / Electromagnetic upper limit switch, lower limit protected through slip clutch
Thermische bescherming / Thermal protection	Geen bescherming / No protection



Electrische Kettingtakel US / Electric Chain Hoist US

Optionele toebehoren / Optional accessories

alleen voor / only for US.901 & US.902



CP0.CEC.0010

10m verlengkabel / 10m extension cable

Om de stuurkabel te verlengen. (max. 2x per takel)

For extending the control cable. (max. 2x per hoist)



CZ.JACKET

Beschermhoes / Protective cover

Voor extra bescherming tegen regen.

For extra protection against rain.



CZ.BOX.US

Opbergbox / Storage box

Voor eenvoudig opslag en transport.

For convenient storage and transportation.

Netto gewicht / Net weight	Afmetingen / Dimensions
kg	mm
24	670 x 580 x 480

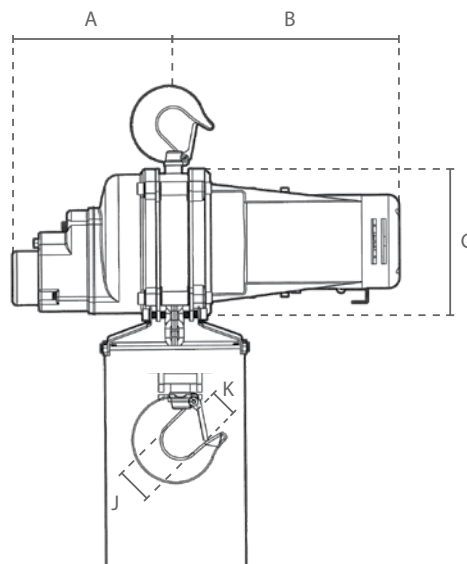
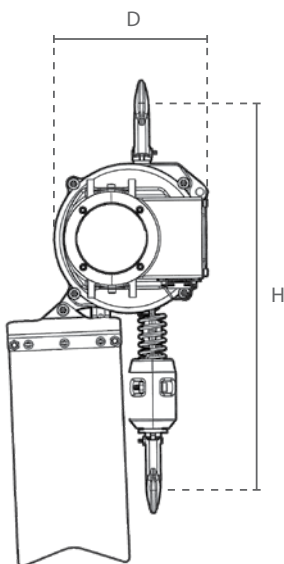

CZ.0.US.901 & 902

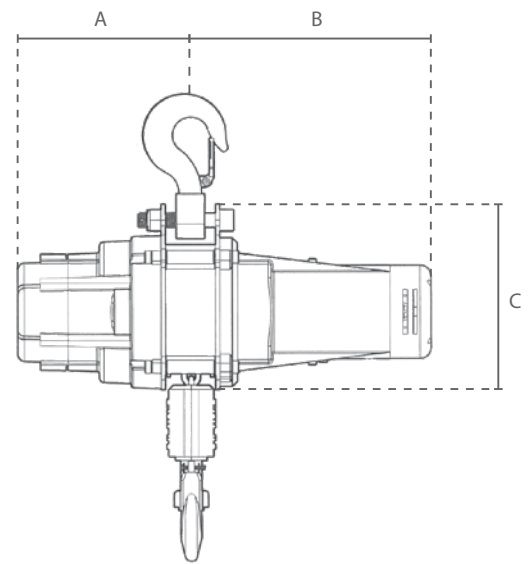

CZ.0.US.903 & 904

Afmetingen / Dimensions							
Artikel nummer / Article code	A	B	C	D	H	J	K
CZ.0.US.901	175	245	165	160	480	38	21
CZ.0.US.902	175	245	165	160	500	38	21
CZ.0.US.903	191	265	206	212	500	39	29
CZ.0.US.904	191	265	206	214	594	46	37



Elektrischer Kettenzug US / Palan électrique à chaîne US

plug & play Funksteuerung /
télécommande plug & play

CZ.0.US

Eigenschaften

- » Ausgelegt für eine Vielzahl von gewerblichen Anwendungen.
- » Einfache Handhabung und hohe Transportfähigkeit durch geringes Gewicht.
- » Schwenkbarer Lasthaken mit Hakensicherung.
- » Betriebsfertig geliefert mit Steuerschalter, Stromkabel und Kettenbehälter.
- » Erfüllt die Maschinenrichtlinie 2006/42/EG. Geliefert mit Prüfzeugnis, CE Konformitätserklärung und Betriebsanleitung.

Caractéristiques

- » Convient à une large gamme d'applications commerciales.
- » Utilisation facile avec grande facilité de transport grâce au poids léger
- » Crochet de charge pivotant avec linguet de sécurité.
- » Livré prêt à l'emploi avec boîte de commande, câble d'alimentation et boîte à chaîne.
- » Conforme à la Directive Machines 2006/42/CE. Livré avec certificat de contrôle, déclaration CE de conformité et mode d'emploi.

Technische Daten / Spécifications

Artikelnummer	Tragfähigkeit	Hubgeschwindigkeit	Lastkette	Kettenstränge	Leistung	Eigengewicht	Zusatzgewicht
Code de l'article	Capacité	Vitesse de levée	Chaîne de levage	Nombre de brins	Puissance	Poids net	Poids supplémentaire
	ton	m/min	Øxmm		kW	kg	kg/m
CZ.0.US.901	0,5	5	6,3 x 19	1	1,3	16	0,9
CZ.0.US.902	1	2,5	6,3 x 19	2	1,3	17	1,8
CZ.0.US.903	1	4	7,1 x 20,2	1	2	26	1,1
CZ.0.US.904	2	2	7,1 x 20,2	2	2	31	2,2

Technische Daten / Spécifications

Betriebsspannung / Tension de fonctionnement	230V / 50-60Hz / 1Ph (110V auf Anfrage/sur demande)
Hubgeschwindigkeit / Vitesse de levée	Haupthub / Simple vitesse
Lastkette / Chaîne de levage	Lastkette nach EN 818-7-DAT/DT / Chaîne de levage selon EN 818-7-DAT/DT
Steuerkabel / Câble de commande	Standard ≈6 Meter / Standard ≈6 mètre
Stromkabel / Câble d'alimentation	≈5 Meter mit Schuko-Stecker / ≈5 mètre avec prise
Schutzart Gehäuse / Protection du boîtier	IP 54
Schutzart Steuerschalter / Protection de la commande	IP 65
Triebwerksgruppe / Classification	M4/1Am (ISO/FEM)
Einschaltdauer / Starts pro Stunde / cycle de service / Démarrages par heure	30% / 180
Isolationsklasse / Classe d'isolation	F
Einsatztemperatur / Température de fonctionnement	-10°C - +40°C
DGUV/BGV Lasttyp / Type de charge	Güter, darf nicht zum Heben von Personen verwendet werden / Marchandises, ne peuvent pas être utilisées pour soulever des personnes

Sicherheit / Protection

Steuerschalter / Commande	Direktsteuerung mit Not-Aus / Interrupteur de commande pendentif 230V avec bouton d'arrêt d'urgence
Überlastschutz / Protection de surcharge	Extern einstellbare Rutschkupplung / Embrayage à friction réglable de l'extérieur
Bremse / Frein	Mechanische Bremse / Frein mécanique
Endabschalter / Fin de course	US.901 + 902: Kein Endabschalter, geschützt durch Rutschkupplung / Pas d'interrupteur fin de course, protégé par l'embrayage à friction US.903 + 904: Elektromagnetischer oberer Endabschalter, untere Hakenposition geschützt durch Rutschkupplung / Fin de course électromagnétique supérieure, limite inférieure protégée par embrayage à friction
Überhitzungsschutz / Protection thermique	Kein Überhitzungsschutz / Pas de protection



Elektrischer Kettenzug US / Palan électrique à chaîne US

Optionales Zubehör / Accessoires en option

nur für / uniquement pour US.901 & US.902



CP0.CEC.0010

10m Verlängerungskabel / 10m Câble d'extension

Zum Verlängern des Steuerkabels. (max. 2x pro Zug)

Pour rallonger le câble de commande. (max. 2x par palan)



CZ.JACKET

Schutzhülle / Housse de protection

Zum zusätzlichen Schutz vor Wind und Wetter.

Pour une protection supplémentaire contre le vent et les intempéries.



CZ.BOX.US

Aufbewahrungsbox / Boîte de rangement

Zur bequemen Aufbewahrung und Transport.

Pour un stockage et un transport pratiques.

Eigengewicht / Poids net	Abmessungen / Dimensions
kg	mm
24	670 x 580 x 480

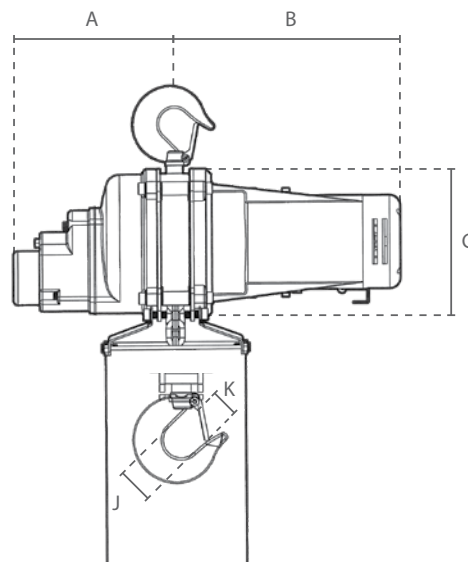
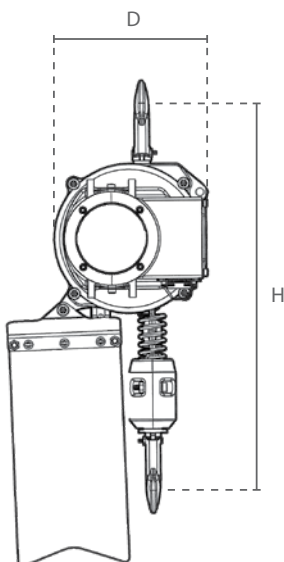

CZ.0.US.901 & 902

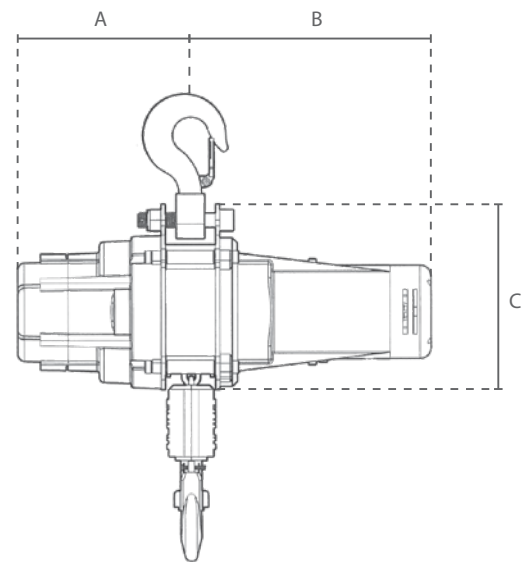

CZ.0.US.903 & 904

Artikelnummer Code de l'article	Abmessungen / Dimensions						
	A	B	C	D	H	J	K
CZ.0.US.901	175	245	165	160	480	38	21
CZ.0.US.902	175	245	165	160	500	38	21
CZ.0.US.903	191	265	206	212	500	39	29
CZ.0.US.904	191	265	206	214	594	46	37



Polipasto Eléctrico de Cadena US / Electric Chain Hoist US



control remoto plug & play / plug & play remote control



CZ.0.US

Características

- » Adecuado para una gran variedad de aplicaciones comerciales.
- » Fácil manejo y alta transportabilidad gracias a su bajo peso.
- » Gancho de carga giratorio con pestillo de seguridad.
- » Se suministra listo para usar con interruptor de control, cable de alimentación y contenedor de cadena.
- » Cumple con la Directiva de Máquinas 2006/42/CE. Se suministra con certificado de pruebas, declaración de conformidad CE e instrucciones de funcionamiento.

Features

- » Suitable for a wide range of industrial applications.
- » Should not be missing in any service van. Makes your service engineer "Health & Safety" proof.
- » Easy handling and high transportability due to low weight.
- » Swivel load hook with safety latch.
- » Supplied ready to use with control switch, power cable and chain container.
- » Complies with the Machinery Directive 2006/42/EC. Supplied with test certificate, CE declaration of conformity and operating instructions.

Especificaciones / Specifications								
Código de artículo	Capacidad	Velocidad de elevación	Cadena de carga	N.º de ramales	Consumo de energía	Peso neto	Peso extra	
Article code	Capacity	Lifting speed	Load chain	Chain falls	Power output	Net weight	Extra weight	
	ton	m/min	Øxmm		kW	kg	kg/m	
CZ.0.US.901	0.5	5	6.3 x 19	1	1.3	16	0.9	
CZ.0.US.902	1	2.5	6.3 x 19	2	1.3	17	1.8	
CZ.0.US.903	1	4	7.1 x 20.2	1	2	26	1.1	
CZ.0.US.904	2	2	7.1 x 20.2	2	2	31	2.2	

Especificaciones / Specifications	
Voltaje / Operating voltage	230V / 50-60Hz / 1Ph (110V bajo demanda/on request)
Velocidad de elevación / Lifting speed	Velocidad única / Single speed
Cadena de carga / Load chain	Cadena de carga según EN 818-7-DAT/DT / Load chain according to EN 818-7-DAT/DT
Cable de control / Control cable	Estándar ≈6 metros / Standard ≈6 meter
Cable de energía / Power cable	≈5 metros con enchufe / ≈5 meter with plug
Protección de la carcasa / Housing protection	IP 54
Protección de control / Control protection	IP 65
Clasificación / Classification	M4/1Am (ISO/FEM)
Ciclo de trabajo / Arranques por hora / Duty cycle / Starts per hour	30% / 180
Clase de aislamiento / Insulation class	F
Temperatura de funcionamiento / Operating temperature	-10°C - +40°C
Tipo de carga / Load type	Mercancías, no se pueden utilizar para levantar personas / Goods, may not be used to lift people

Protección / Protection	
Interruptor de control / Control switch	230V interruptor con botón de parada de emergencia / 230V pendant control switch with emergency stop button
Protección de sobrecarga / Overload protection	Embrague de deslizamiento ajustable externamente / Externally adjustable slip clutch
Freno / Brake	Freno mecánico / Mechanical brake
Interruptor de límite / Limit switch	US.901/902: Sin interruptor de límite, asegurado por embrague deslizante / No limit switch, protected through slip clutch US.903/904: Interruptor de límite superior electromecánico, final de carrera inferior asegurado por embrague deslizante / Electromagnetic upper limit switch, lower limit protected through slip clutch
Protección térmica / Thermal protection	Sin protección / No protection



Polipasto Eléctrico de Cadena US / Electric Chain Hoist US

Accesorios opcionales / Optional accessories

solo para / only for US.901 & US.902



CP0.CEC.0010



CZ.JACKET



CZ.BOX.US

10m Cable de extensión / 10m Extension cable

Para extender el cable de control. (máx. 2x por polipasto)

For extending the control cable. (max. 2x per hoist)

Cubierta protectora / Protective cover

Para una protección adicional contra el viento y las inclemencias del tiempo.

For extra protection against rain.

Caja de almacenaje / Storage box

Caja de almacenamiento, para un almacenamiento y transporte convenientes.

For convenient storage and transportation.

Peso neto / Net weight	Dimensiones / Dimensions
kg	mm
24	670 x 580 x 480

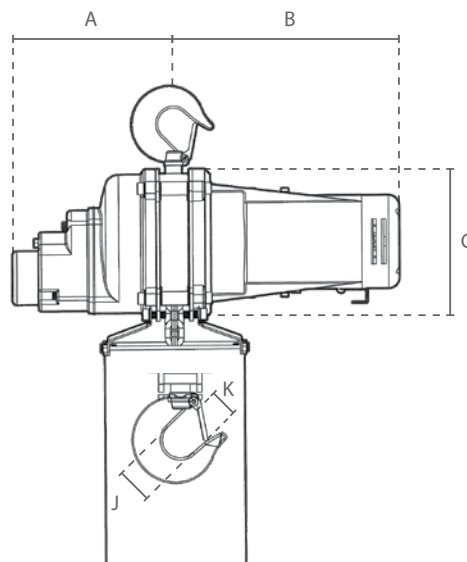
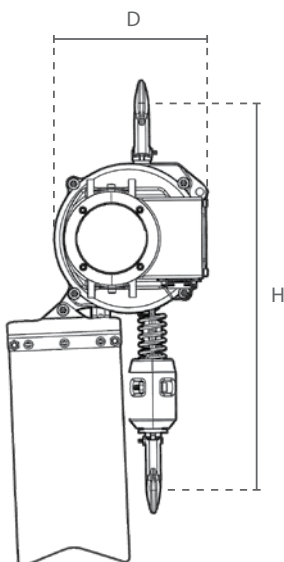

CZ.0.US.901 & 902

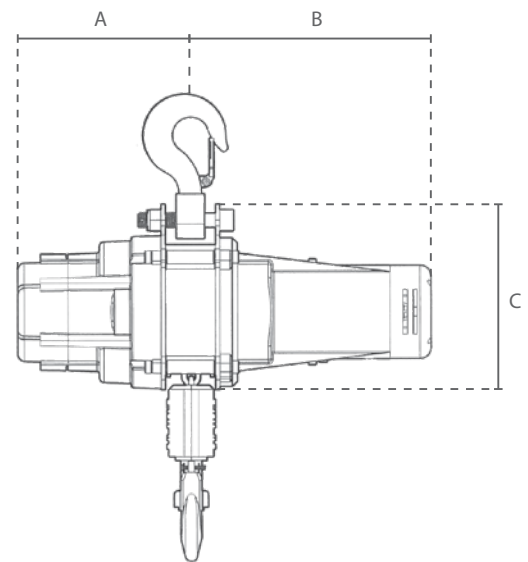

CZ.0.US.903 & 904

Código de artículo Article code	Dimensiones / Dimensions						
	A	B	C	D	H	J	K
CZ.0.US.901	175	245	165	160	480	38	21
CZ.0.US.902	175	245	165	160	500	38	21
CZ.0.US.903	191	265	206	212	500	39	29
CZ.0.US.904	191	265	206	214	594	46	37